

# 450 Series Overview / Features

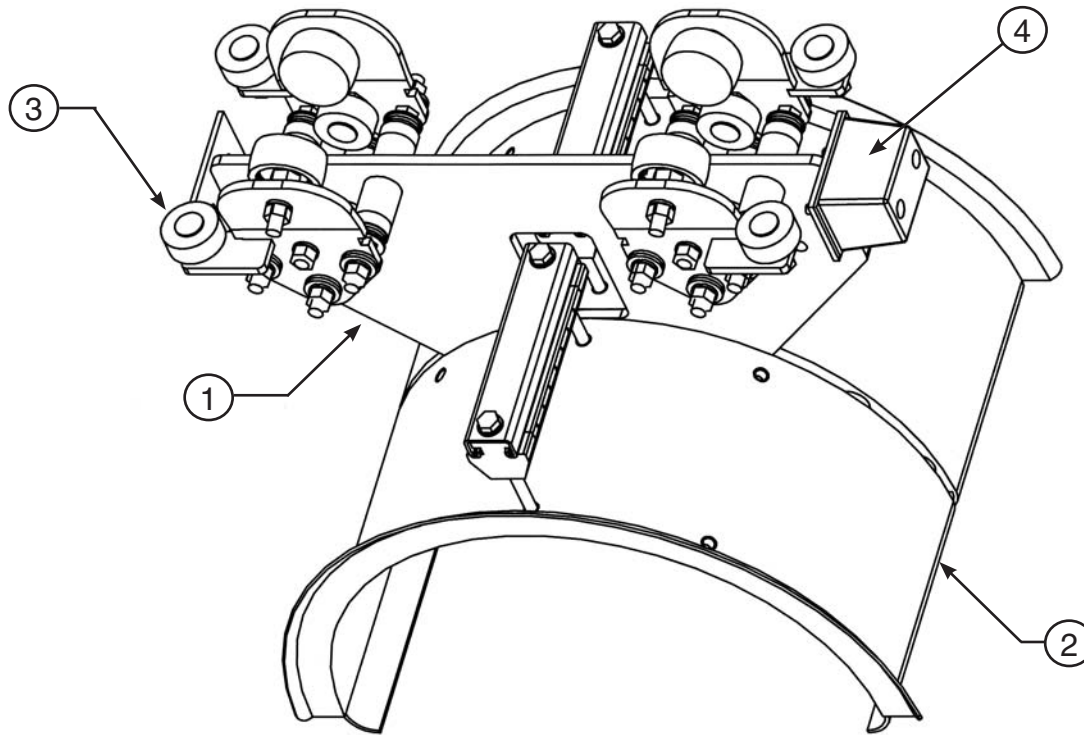

## 1) Center Plate

Material: 3/8" Hot Rolled Steel  
Finish: Hot Dipped Galvanized

## 2) Saddle Assembly

Material: 12 Gauge Steel  
Finish: Hot Dipped Galvanized  
Features: • Formed Saddle from single piece of steel, no welds  
• Saddle has rolled flanges with rounded edges, won't cut cables  
• Saddles bolted to center plate with stainless steel fastener  
• Saddles available with either single or double cable clamping bar

## 3) Running Gear

### Side Shields:

Material: 5/16" Hot Rolled Steel  
Finish: Hot Dipped Galvanized  
Features: • Bolted to center plate with stainless steel fastener  
• Independently removable

### Rollers:

Material: Hardened Steel  
Finish: Zinc Plated  
Bearings: Permanently Sealed, Ball Bearings  
Feature: Available with polyurethane tires for quiet travel and minimal beam wear

## 4) Bumper

Material: Neoprene Rubber  
Durometer: 65-70 ShoreA  
fastener: Stainless Steel  
Feature: Large contact surface area