

# Airflex® Dual Passage Rotorseals

## Section J

### Component Part Descriptions

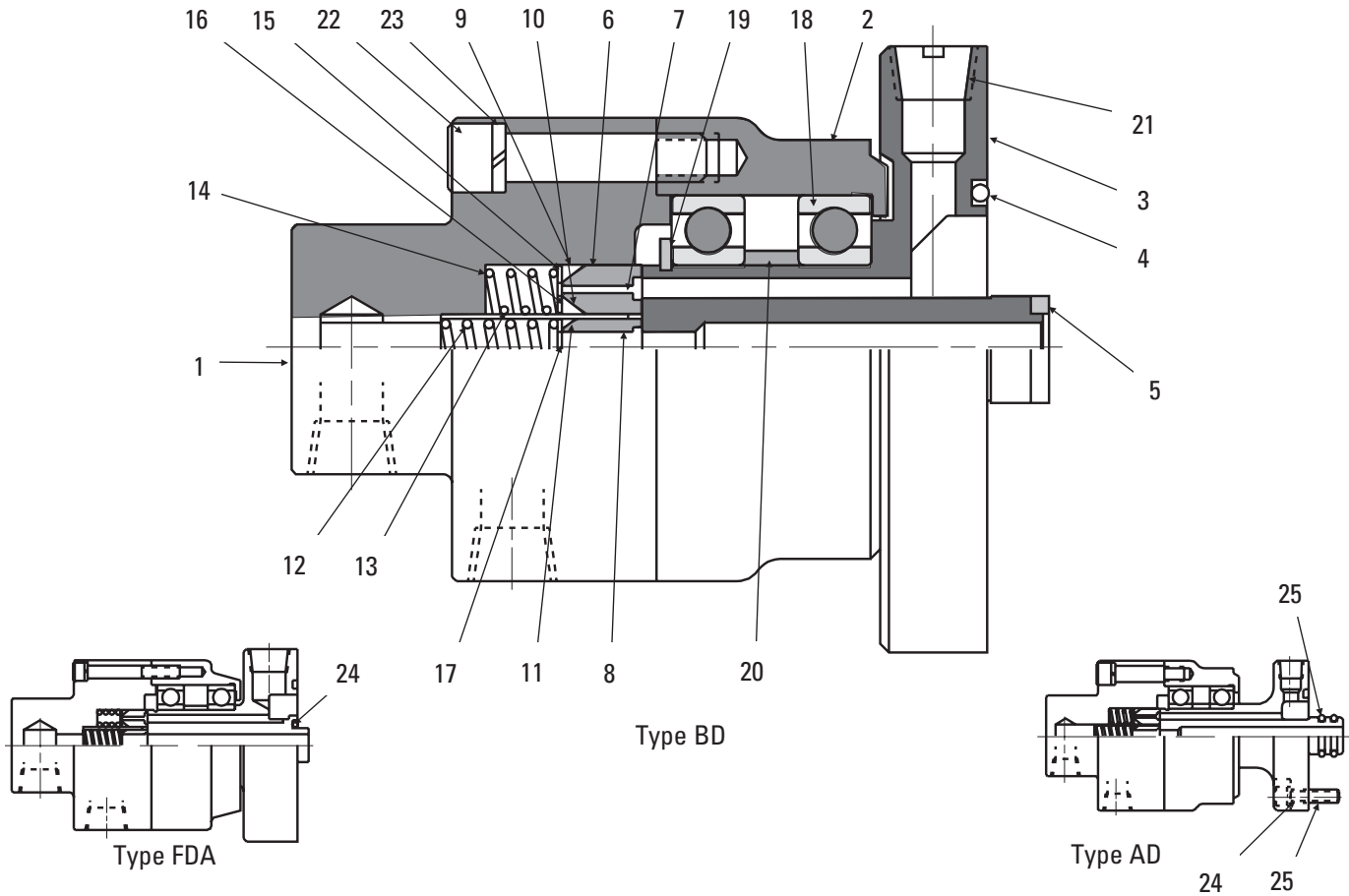

Item	Description
1	Rear Housing and Spring Retainer Assembly
2	Front Housing
3	Shaft
4*	Grommet
5*	Grommet
6*	Outer Carbon
7*	Intermediate Carbon
8*	Inner Carbon
9*	Outer "O" Ring
10*	Intermediate "O" Ring
11*	Inner "O" Ring
12*	Inner Seal Spring
13*	Intermediate Seal Spring
14*	Outer Seal Spring

Item	Description
15*	Outer Spring Retainer Ring
16*	Intermediate Spring Retainer Ring
17*	Inner Spring Retainer Ring
18	Bearing
19	Snap Ring
20	Bearing Spacer
21	Pipe Plug
22	Socket Head Cap Screw
23	Lockwasher
24*	Grommet
25*	Grommet
26	Hex or Socket Head Cap Screw
27	Lockwasher
*	Seal Kit (includes items marked *)