

Airflex® DBB Description

Section E

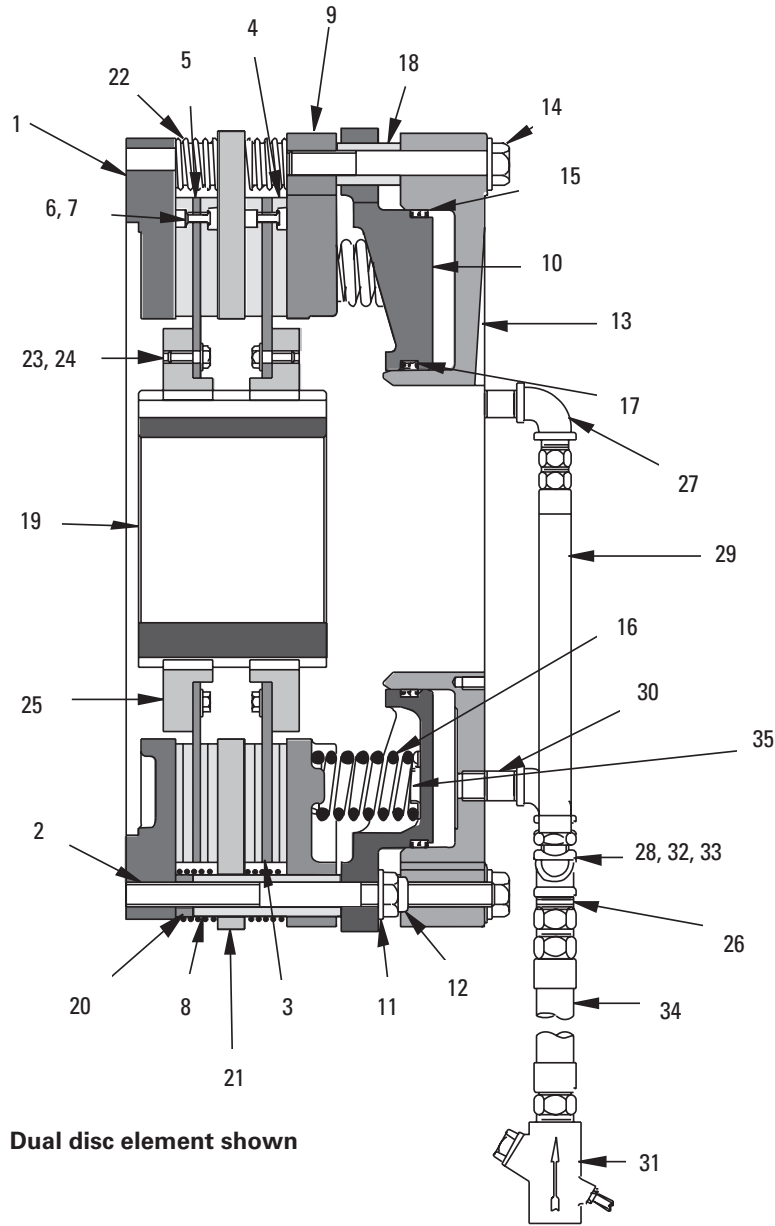

Item Number	Description
1	Mounting Flange
2	Stud
3	Friction Disc Sub-Assembly
4	Friction Disc
5	Friction Disc Core
6	Rivet
7	Washer
8	Clamp Tube
9	Pressure Plate
10	Spring Housing
11	Flat Washer
12	Locknut

Item Number	Description
13	Cylinder
14	Hex Head Screw
15	Outer Seal
16	Spring
17	Inner Seal
18	Spacer Tube
19	Gear
20	Wear Spacer
21	Reaction Plate
22	Release Spring
23	Flat Washer
24	Hex Head Screw

Item Number	Description
25	Ring Gear
26	Pipe Nipple
27	Elbow
28	Pipe Cross
29	Hose Assembly
30	Pipe Nipple
31	Flow Control Valve
32	45 Deg. Street Elbow
33	Pipe Reducer
34	Hose Assembly
35	Spring Retainer